

K TWIN IMPELLER PUMPS



Twin impeller centrifugal pump designed for use in pressurisation units for water supply systems for domestic, civil and industrial use. Suitable for sprinkling irrigation and other water supply applications. Cast iron pump body and motor support. Technopolymer impeller.

Stainless steel driving shaft. Carbon/ceramic mechanical seal.

Asynchronous, closed motor, cooled by external ventilation.

Built-in thermal and current overload protection and a capacitor permanently on in the single-phase version. For the protection of the three-phase motor it is advisable to use a suitable overload protection complying with the regulations in force.

Operating range: from 1.5 to 10,8 m³/h with head up to 60 metres.



K 45/50 M

Pumped liquid characteristics: clean, free from solids or abrasive substances, not viscous, not aggressive, not crystallised, chemically neutral and close to the characteristics of water.

Liquid temperature range: K 35/40, K 45/50: from -10°C to +50°C
K 35/100, K 40/100, K 55/50: from -15°C to +110°C

Maximum ambient temperature: +40°C

Protection level: IP 44

Terminal board protection level: IP 55

Insulation class: F

Maximum operating range: K 35/40, K 35/100, K 40/100 6 bar (600 kPa)
K 45/50, K 55/50 8 bar (800 kPa)

TECHNICAL DATA

MODEL	ELECTRICAL DATA						
	VOLTAGE 50 Hz	P1 MAX kW	P2 NOMINAL kW HP		I _n A	CAPACITOR μF V _c	
K 35/40 M	1x220-240 V ~	1,2	0,75	1	5,5	20	450
K 35/40 T	3x230-400 V ~	1,2	0,75	1	3,8-2,2	-	-
K 45/50 M	1x220-240 V ~	1,86	1,1	1,5	8,3	31,5	450
K 45/50 T	3x230-400 V ~	1,96	1,1	1,5	6-3,5	-	-
K 55/50 M	1x220-240 V ~	2,7	1,85	2,7	12,8	40	450
K 55/50 T	3x230-400 V ~	2,5	1,85	2,5	8,4-4,8	-	-
K 35/100 M	1x220-240 V ~	1,56	1,1	1,5	7,1	25	450
K 35/100 T	3x230-400 V ~	1,56	1,1	1,5	5,36-3,1	-	-
K 40/100 M	1x220-240 V ~	2	1,85	2,5	9	40	450
K 40/100 T	3x230-400 V ~	2	1,85	2,5	6,2-3,6	-	-

* Star (Δ) starting is possible

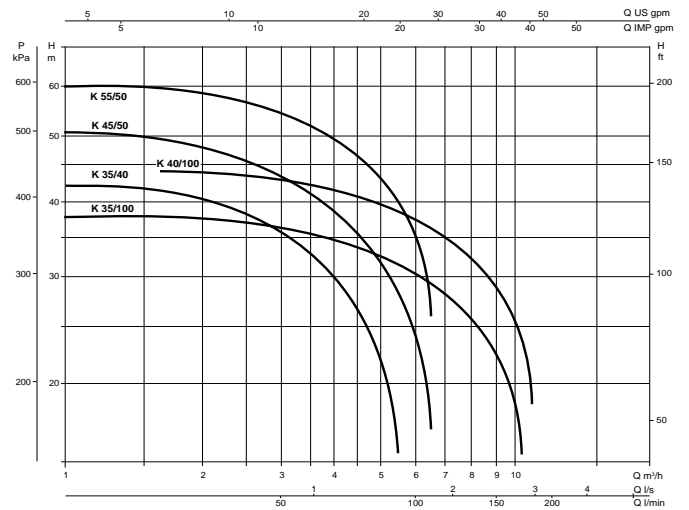

DIMENSIONS AND WEIGHTS

K 35/40 - K 45/50 - K 55/50

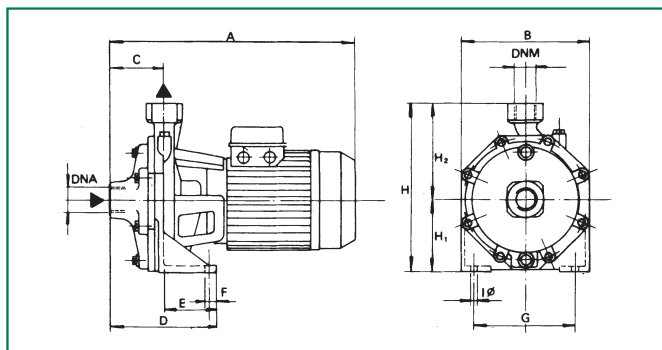

K 35/100 - K 40/100

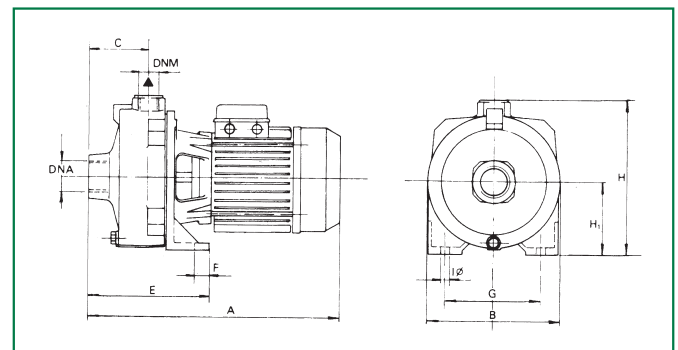

MODEL	A	B	C	D	E	F	G	Ø I	H	H1	H2	DNA	DNM	WEIGHT Kg
K 35/40	342	180	76	148	72	15	148	9,5	235	100	135	1" G	1" G	15,9
K 45/50	370	210	75	144	69	15	165	11,5	268	118	150	1 1/4" G	1" G	23,3
K 55/50	370	210	75	114	69	15	165	11,5	268	118	150	1 1/4" G	1" G	23,8
K 35/100	387	205	88	-	179	20	145	11	233	108	-	1 1/2" G	1" G	21,5
K 40/100 M	461	205	88	-	179	20	145	11	233	108	-	1 1/2" G	1" G	25,9
K 40/100 T	387	205	88	-	179	20	145	11	233	108	-	1 1/2" G	1" G	22